

MODULAR LABS & CLEANROOMS

Sized to suit your space requirements, pre-engineered for prompt on site assembly. Equipped with HVAC system, lighting & electrical service to specs. HEPA filtered supply air to suit your modular clean lab applications.



HEMCO pre-engineered modular construction for prompt on-site assembly to meet lab space requirements, easily expanded and relocated to suit future Lab Planning needs providing space and energy savings, Now and in the future.



HEMCO

Laboratory Planning Solutions

For Prompt
Service Call: (816) 796-2900

www.HEMCOcorp.com

UNILAB MODULAR CLEAN LABS

UNILAB MODULAR CLEAN LABS

UNILAB MODULAR CLEAN LABS

UNILAB MODULAR CLEAN LABS

UNILAB MODULAR CLEAN LABS

UNILAB MODULAR CLEAN LABS

UNILAB MODULAR CLEAN LABS

UNILAB MODULAR CLEAN LABS



Electronics Modular Clean Lab, Class 1000, with airlock



Tissue Culture Modular Clean Lab, Class 10,000,



Hazardous Safety Modular Clean Lab, HEPA in-HEPA out

- Where critical levels of cleanliness must be maintained, HEMCO UniLab pre-engineered modular system offers a cost-effective alternative to conventional construction while providing quality, durability and modular clean lab performance.

- HEMCO UniLab Modular Clean Lab modulares are movable and expandable and to provide years of usability and versatility.

- HEMCO UniLab Modular Clean Lab wall systems can interface with the modular clean lab floor, ceiling and mechanical components to provide a clean workspace that maintains optimum airflow, pressure, temperature, humidity and cleanliness.

- HEMCO UniLab Modular Clean Labs can also be free standing structures, independent of the surrounding area. Rooms can be engineered to meet special size requirements.



Quality Control Laboratory

- At HEMCO, we understand your needs. Modular construction allows fast, easy installation as well as design flexibility to meet your changing needs without sacrificing quality.

- HEMCO UniLab Modular Clean Lab systems are built to your exact specifications to ensure optimal performance. Pre-engineered modular design minimizes construction costs and delays.

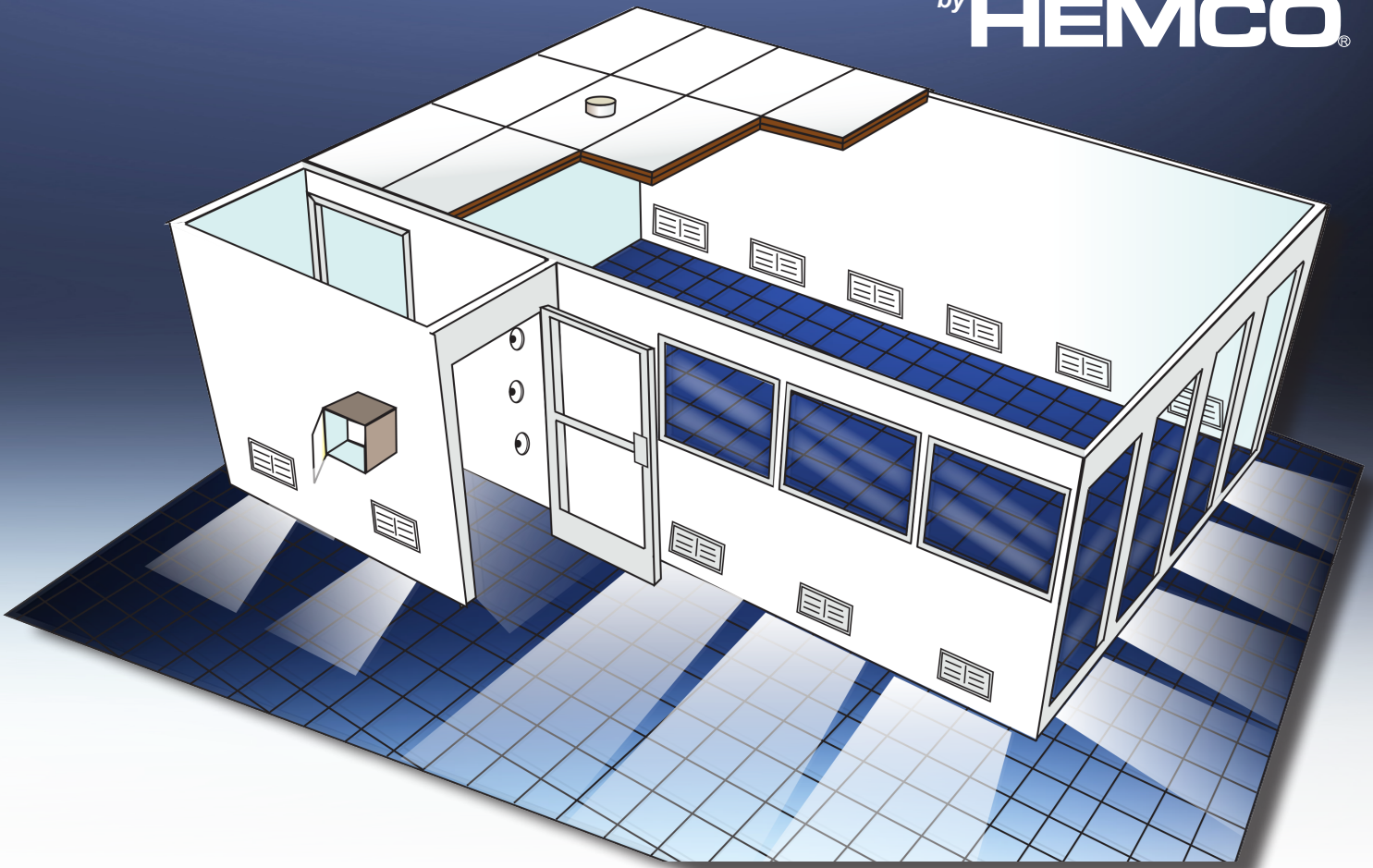

Clean Lab, Class 100, with airlock



**Weighing / Dispensing
Modular Clean Lab,
Class 10000, with filtered airlock**



Calibration Clean Lab

CONSTRUCTION FEATURES

- Wall and ceiling panels are chemical resistant, smooth and non-porous for easy cleaning and decontamination. Panel surfaces can be constructed of fiberglass, stainless steel, coated steel or aluminum.
- Convenient access to HEPA filters and lighting allows them to be serviced from inside the room.
- Special airlocks, gowning areas and pass-throughs can be designed into the modular clean lab.

CONCEPT TO COMPLETION

- HEMCO's experienced technical staff will gladly assist in the design and engineering of your clean room from concept to completion.
- Technical staff will work closely with you to answer questions or suggest solutions, helping to develop a modular clean lab to your exact specifications. Visit our website at www.hemcocorp.com to request a HEMCO Modular Clean Lab Specification Planner.

Quick Ship UniLab Modular Clean Labs

HEMCO UniLab Modular Clean Lab Room Structures are innovative, pre-engineered modular laboratory workspaces with HEPA filtered supply air, built to your exact process, size and design requirements, for ventilation and safety.



6' X 8' QC Lab w/base floor



8' X 12' Calibration Lab



10' X 16' Clean Lab

MODULAR HEPA CLEAN LABS AND APPLICATIONS

- **Industrial Quality Control Laboratory**
- **Hazardous Materials Testing**
- **CMM/Calibration Lab**
- **Designated Control Rooms**
- **Additional Lab Space**

As technologies change, companies need facilities that can immediately be put into use or quickly adapt with a minimum amount of installation, time, and cost.

The UniLab Modular Clean Lab features a pre-engineered modular wall panel system that is a cost effective and time efficient alternative to traditional construction. It gives you a fully equipped, high quality enclosure that is easily expanded or relocated as needs change. Determine where the room should be located, assemble the ModuLab, connect services and start your process.

The UniLab Modular Clean Lab can fit a wide range of applications. Wall panel options are available to meet thermal, chemical resistance, sound, and fire control requirements. Room roof panels can offer load bearing capacity and suspended ceiling systems are available for pressurized overhead supply plenums.

UniLab Modular Clean Labs can be shipped knocked-down to fit through a standard doorway for easy on-site erection. If desired, it can be shipped pre-assembled for turnkey operation complete with laboratory fume hoods, furniture, and all component equipment to meet your laboratory requirements.

You can detail your specific requirement on our convenient specification planner. Request an Innovative Modular Labs and Rooms catalog at www.HEMCOcorp.com.



**HEPA Filtered,
Clean Rooms Class 100,000**

**Optional
Airlock Room**

SPECIFICATIONS

ROOM CONSTRUCTION FEATURES: wall panels are Class A and are mounted into a clear anodized aluminum framing. Standard wall panels are 48" w x 120" h x 3" thick and are constructed with a foam core sealed between 1/2" gypsum and surfaced with chemical resistant composite resin panels with smooth white finish. Available with optional Room.

T-GRID CEILING SYSTEM: 1-1/2" Aluminum ceiling grid with white painted finish positioned 8' above floor. Includes all connectors, suspension hardware to hang from corrugated steel roof deck.

MYLAR CEILING PANELS: have sealed edges for spaces not occupied by fan filter units or light fixtures.

ENTRY DOOR: (1) 36" W X 80" H Door with viewing window, passage lever and hinges & lock.

WINDOWS: Nominal 46" W X 39" H, 1/4" tempered glass, mounted in an anodized aluminum frame. (optional windows can be added to meet your specs)

LIGHTING: LED 2' X 4' panel light fixtures, ceiling mount, 115V.

SINGLE-PASS DESIGN: Ambient surrounding air is drawn into the Clean Room Fan Filter Units at the ceiling level. The filtered air passes into the clean lab and is transferred out of the room through either the fume hood or general exhaust grills. Room is clean but under slight negative pressure.

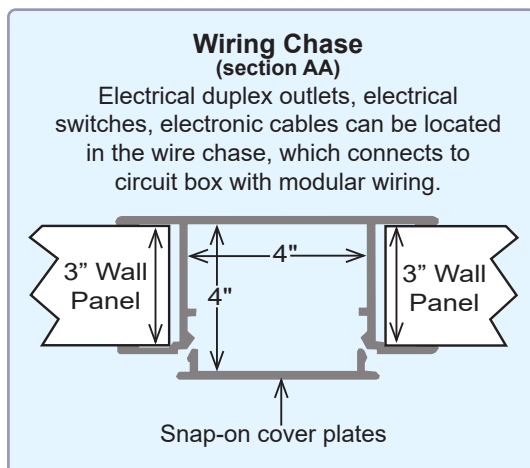

HEPA FILTERED SUPPLY AIR: 2' X 4' Fan Filter units, Module features a 99.99% efficient @ 0.3 micron HEPA filter with, 90 FPM @ initial 0.47 w.g., 115v low watt A/C, 60Hz 1ph, includes prefilter, on/off/variable speed control, powder coated steel housing.

CLEAN AIR IN-LINE CARBON FILTRATION EXHAUST AIR: Filters are loaded with virgin coconut activated carbon to efficiently absorb organic solvents and acid fumes. The filter pack housing features a hinged access door with gaskets and spring latches for convenient filter changes.

EXHAUST BLOWERS: Standard (STD) belt drive steel blower and impeller wheel are epoxy coated for superior chemical resistance. Explosion-proof blowers (EXP) have epoxy coated, non-sparking aluminum impeller wheel. V-belt drive and adjustable pulleys permit field balancing.

Plan View Room #1 Cat. No. 80812 (12' X 8' X 10')

Room 1 includes: laboratory base cabinets, worksurfaces (black). Request a tech data sheet for room specifications. Maximum Occupancy 1-2 people.

Cat. No. 80812 Room #1 Description

12'w X 8'd x 10' h Modular Lab with 8' ceiling

Solid Walls are 3' thick with smooth PVC on 1/2" gypsum with rigid foam core

(1) Door shall be 3' W X 7' h, painted steel, hinged door, half glass

(2) LED flat panel light fixture 2' X 4', 115V with modular wiring 115V

(1) Filtration module, 2' X 4', with 99.99% efficient HEPA filter, prefilter integral fan and speed control 115V

(2) Windows are 1/4" tempered glass

(4) Duplex receptacles and light switch with modular wiring

(1) Circuit box, 100 amp, 6 circuits with modular wiring

(2) Data (cabling not included)

(1) Changing Room, construction same as room construction except (1) additional LED light & switch

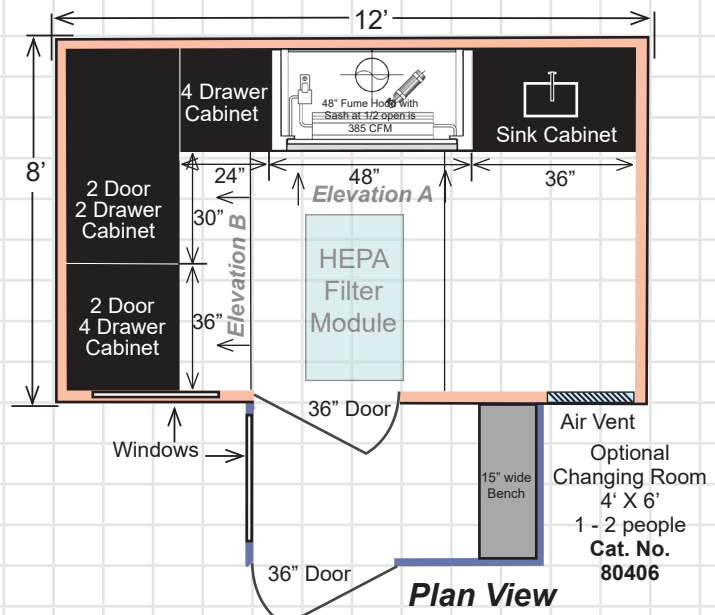

Laboratory Furniture Specifications for Room #1 Cat.No.80812		
Elevation A		
Cat. No	Description	Qty
35463	48" LE Fume Hood	1
71222	24" 4 Drawer Cabinet	1
54811	48" 2 Door Cabinet	1
71812	36" Sink Unit	1
50026	Faucet	1
42022	Sink 16" X 12"	1
70018B	Phenolic Worksurface & Backsplash	1
Elevation B		
71102	36" 4 Drawer 1 Door Cabinet	1
71062	30" 2 Door 2 Drawer Cabinet	1
70018B	Phenolic Worksurface & Backsplash	1

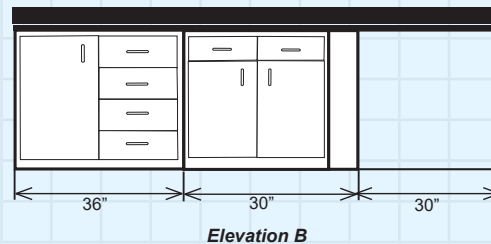
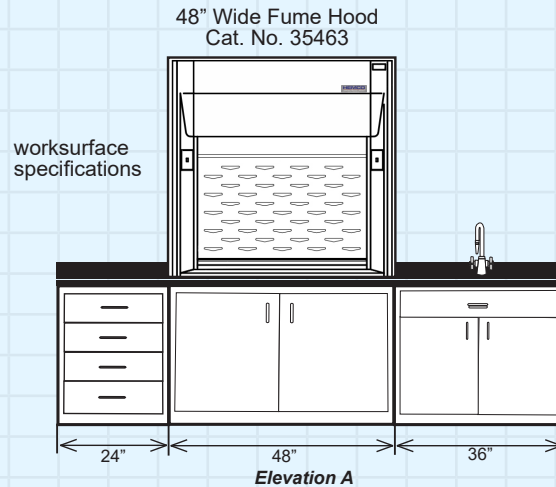

Elevation View of Laboratory Furniture Layout

Note: Exhaust Blowers and carbon filtration modules are available to safely exhaust and filter odors from the fume hood. Knowing the length of the ducting and the number of elbows in the duct run will enable us to properly size the blower and filter module to your specific requirement.

Plan View Room #2 Cat. No. 81216 (16' X 12' X 10')

Room 2 includes: laboratory base cabinets, worksurfaces (black). Request a tech data sheet for room specifications. Maximum Occupancy 3-4 people.

Cat. No. 81216 Room #2 Description

16'w X 12'd x 10' h Modular Lab with 8' ceiling

Solid Walls are 3" thick with smooth PVC on 1/2" gypsum with rigid foam core

(1) Door shall be 3' W X 7' h, painted steel, hinged door, half glass

(2) LED flat panel light fixture 2' X 4', 115V with modular wiring 115V

(1) Filtration module, 2' X 4', with 99.99% efficient HEPA filter, prefilter integral fan and speed control 115V

(2) Windows are 1/4" tempered glass

(6) Duplex receptacles and light switch with modular wiring

(1) Circuit box, 100 amp, 6 circuits with modular wiring

(2) Data (cabling not included)

(1) Changing Room, construction same as room construction except (1) additional LED light & switch

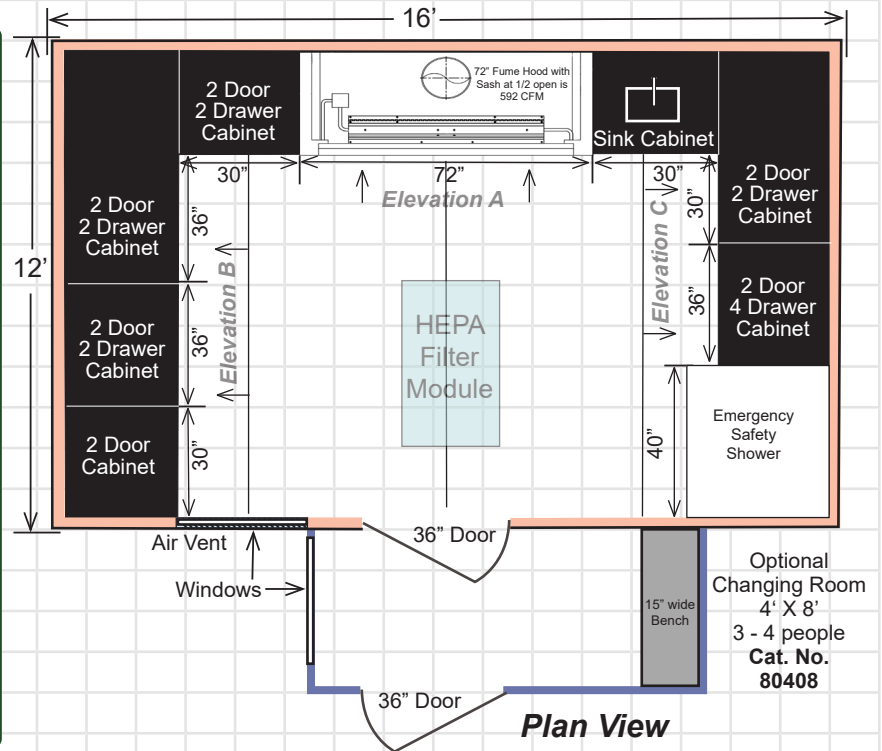

Laboratory Furniture Specifications for Room #2 Cat.No.81216		
Elevation A		
Cat. No	Description	Qty
35563	72" LE Fume Hood	1
74112	7" Filler Panel	2
71061	30" 2 Door 2 Drawer	1
71062	36" 2 Door Cabinet	2
71811	30" Sink Unit	1
50026	Faucet	1
42022	Sink 16" X 12"	1
70018B	Phenolic Worksurface & Backsplash	1
Elevation B		
71062	30" 2 Door Cabinet	1
71062	36" 2 Door 2 Drawer Cabinet	2
74112	7" Filler Panel	1
70018B	Phenolic Worksurface & Backsplash	1
Elevation C		
74112	7" Filler Panel	1
71061	30" 2 Door 2 Drawer	1
71102	36" 1 Door 4 Drawer	1
70018B	Phenolic Worksurface & Backsplash	1
16601	40" Safety Shower	1

Note: Exhaust Blowers and carbon filtration modules are available to safely exhaust and filter odors from the fume hood. Knowing the length of the ducting and the number of elbows in the duct run will enable us to properly size the blower and filter module to your specific requirement.

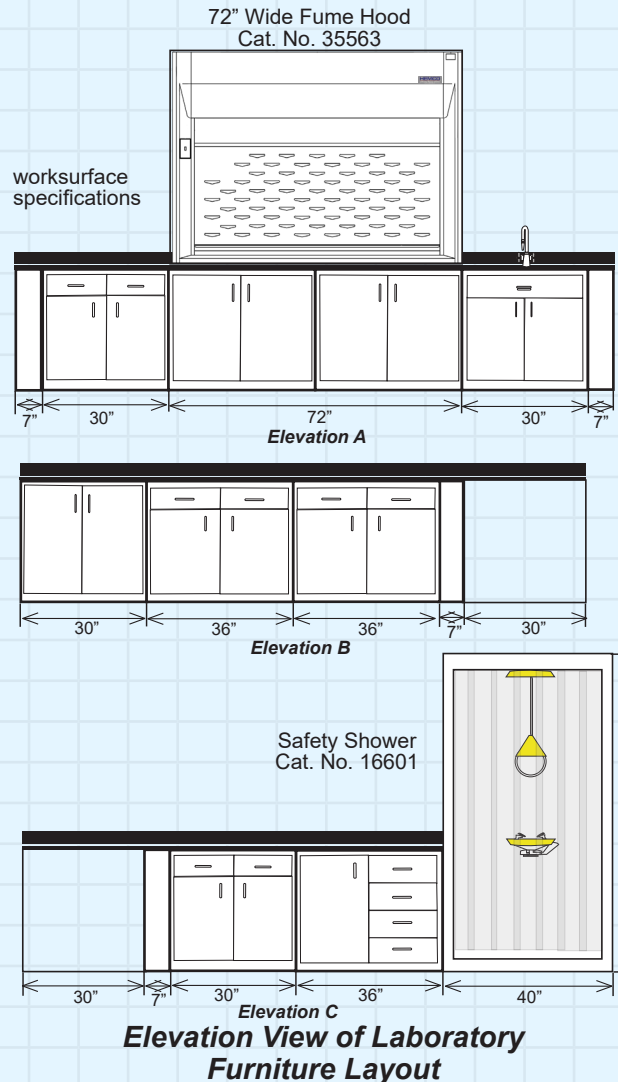

Plan View Room #3 Cat. No. 81624 (24' X 16' X 10')

Room 3 includes: laboratory base cabinets, worksurfaces (black). Request a tech data sheet for room specifications. Maximum Occupancy 5-7 people.

Cat. No. 81624 Room #3 Description

24'w X 16'd x 10' h Modular Lab with 8' ceiling

Solid Walls are 3' thick with smooth PVC on 1/2" gypsum with rigid foam core

(1) Door shall be 3' W X 7' h, painted steel, hinged door, half glass

(3) LED flat panel light fixture 2' X 4', 115V with modular wiring 115V

(2) Filtration modules, 2' X 4', with 99.99% efficient HEPA filter, prefilter integral fan and speed control 115V

(4) Windows are 1/4" tempered glass

(10) Duplex receptacles and light switch with modular wiring

(1) Circuit box, 100 amp, 6 circuits with modular wiring

(2) Data (cabling not included)

(1) Changing Room construction same as room construction except
(1) additional LED light & switch

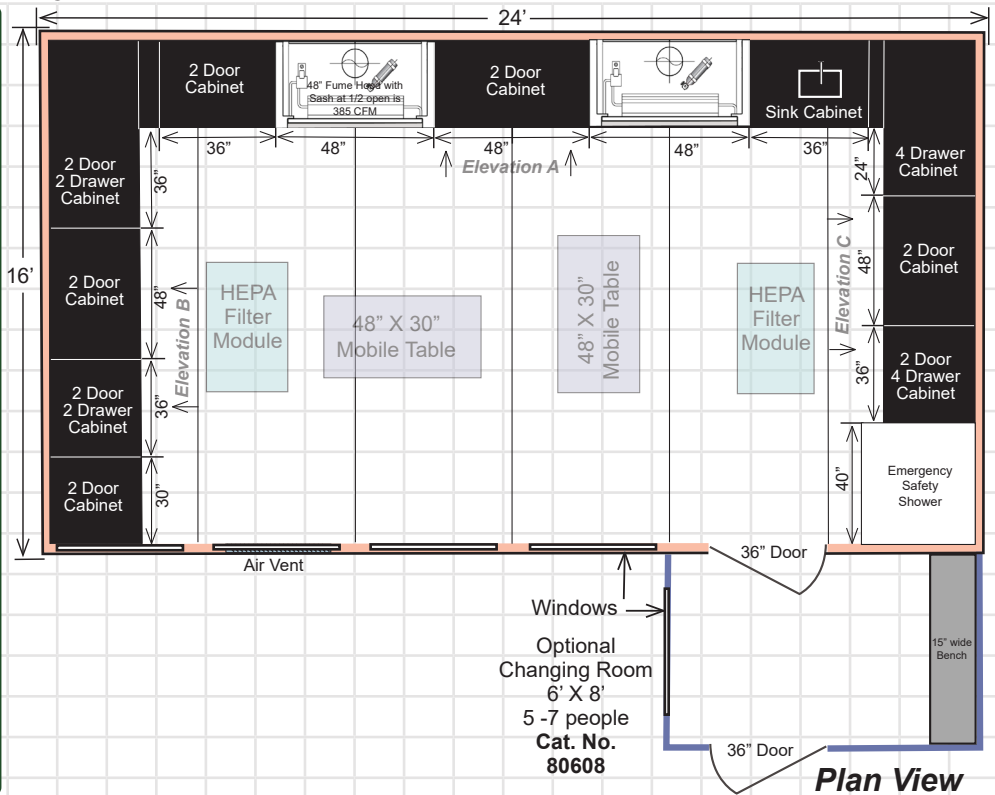

Laboratory Furniture Specifications for Room #3 Cat.No.81624

Elevation A		
Cat. No	Description	Qty
35463	48" LE Fume Hood	2
71062	36" 2 Door Cabinet	1
54811	48" 2 Door Cabinet	3
71812	36" Sink Unit	1
74112	7" Filler Panel	1
50026	Faucet	1
42022	Sink 16" X 12"	1
70018B	Phenolic Worksurface & Backsplash	1

Elevation B		
Cat. No	Description	Qty
71062	30" 2 Door Cabinet	1
71062	36" 2 Door 2 Drawer Cabinet	2
54811	48" 2 Door Cabinet	1
74112	7" Filler Panel	1
70018B	Phenolic Worksurface & Backsplash	1

Elevation C		
Cat. No	Description	Qty
74112	7" Filler Panel	1
71222	24" 4 Drawer	1
54811	48" 2 Door Cabinet	1
71062	36" 2 Door 2 Drawer Cabinet	1
16604	40" Safety Shower	1
70018B	Phenolic Worksurface & Backsplash	1

Note: Exhaust Blowers and carbon filtration modules are available to safely exhaust and filter odors from the fume hood. Knowing the length of the ducting and the number of elbows in the duct run will enable us to properly size the blower and filter module to your specific requirement.

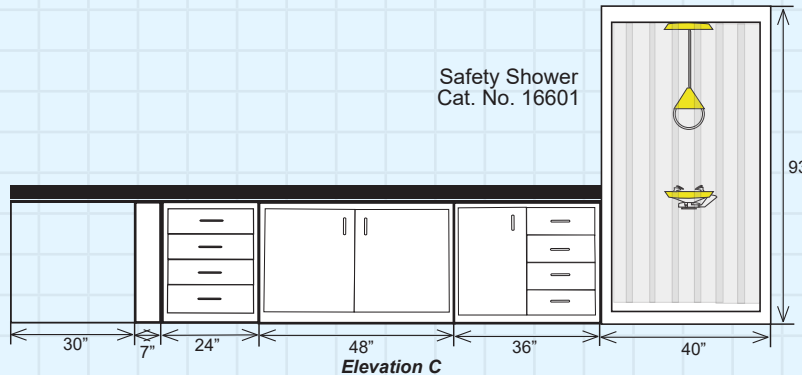
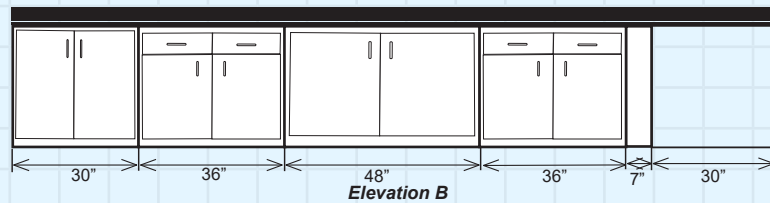
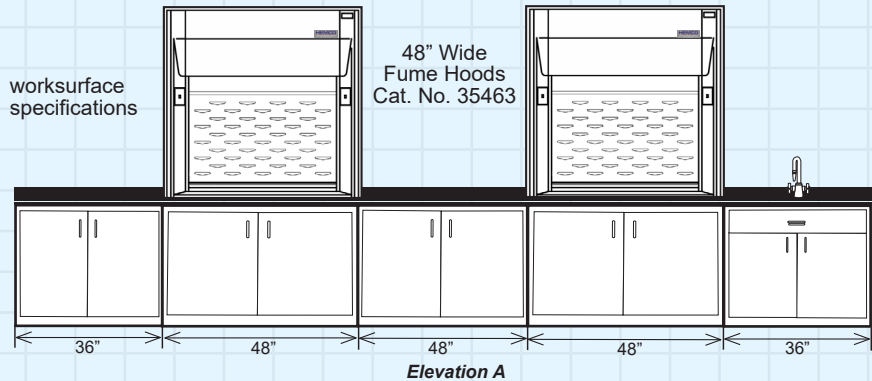

Elevation View of Laboratory Furniture Layout

UniFlow LE AireStream Laboratory Fume Hoods



High efficiency, full duty fume hood in 48" and 72" widths. UniFlow LE AireStream Fume Hoods are low flow constant volume for energy savings & maximum user protection. Requires Remote Exhaust Blower. Hood is U.L.1805 classified.

Phenolic Resin Worksurface 1 1/4" thick, dished, supplied and factory installed to bottom of hood.

UniFlow LE AireStream Fume Hoods			
Width	Depth	Height	Cat. No.
48"	30"	48"	35463
60"	30"	48"	35563
72"	30"	48"	35663
96"	30"	48"	35863

Optional sizes available to your specs.

VaraFlow Air Bypass low flow, constant air volume hood. Dual wall unitized construction, all non-metallic corrosion and fire resistant composite construction. Molded one-piece fume chamber with white glass-smooth surface with all covered corners.

Vector AireStream Baffle System and bell shaped exhaust collar.

Sash to be counterbalanced, 3/16" tempered safety glass with chemical resistant non-metallic PVC framing, track & aerodynamic sash lift.

Sash Stop at half open for energy efficiency and user protection. A sash stop is installed at the half open position.

28" Vertical Sash Height provides ease of access for apparatus set-up in fume chamber. Standard Sash. 32" Viewing Height interior fume chamber with 24" interior reach in depth.



UniFlow LE AireStream Hood Cat. No. 35663 shown with factory installed phenolic resin worksurface, base cabinet and fixtures.

Fume Hood Base Cabinets



Explosion-Proof Light Std Class I Div II For use in hazardous locations. Gray, two-coat epoxy finish with easily removed prismatic globe. Factory mounted, not wired. Accepts compact fluorescent or LED, (bulb not included) 115V /230V UL listed. Class I Div II Group A, B,C,D Class II Div II Group F & G



ABC Dry Chemical Fire Extinguishers with automatic activation at 165° Fahrenheit, dry chemical Monoammonium Phosphate, 10 lb.....**Cat No. 53030**



Base Cabinet Constructed of furniture grade steel. With adjustable shelf and levelers. Doors feature double wall construction. Standard depth is 22", standard height is 35". White powder coat finish.

Width	Cat. No.
30"	53011
36"	53611
48"	54811
Filler Panels (2)	74112
Door Lock	75001



Acid Cabinet provides safe storage of acids. Molded furniture grade one piece chemical resistant, composite liner, covered corners, glass smooth for ease of cleaning. Standard depth is 22", standard height is 35". White powder coat finish.

Width	Doors	Cat. No.
30"	2	15300
36"	2	15360
48"	2	15480
Vent Kit	---	81000
Filler Panels (2)		74112
Door Lock		75001



Flammable Cabinet provides safe storage of flammables. Constructed of welded double wall furniture grade steel. Standard depth is 22", standard height is 35". White powder coat finish. With locking handle.

Width	Cat. No.
30"	18300
36"	18030
48"	18040
Filler Panels (2)	74112

When Flammable cabinets are vented it voids UL Listing. Sealed doors smother any flame.

Laboratory Base Cabinets & Worksurfaces

Lab cabinets are offered in standard modular sizes that allow you to create a custom laboratory to meet your specific needs. Cabinets feature furniture grade welded steel construction with a durable, chemical resistant, epoxy powder coat finish. **Base Cabinets (standard color: Lab White)**

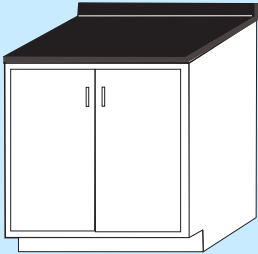

2 Door

Width	Depth	Cat. No.
30"	22"	53011
36"	22"	53611
48"	22"	54811



2 Drawer - 2 Door

Width	Depth	Cat. No.
30"	22"	71061
36"	22"	71062
48"	22"	71064



4 Drawer - 1 Door

Width	Depth	Cat. No.
30"	22"	71101
36"	22"	71102
48"	22"	71104





Sink Unit Cabinet

Width	Depth	Cat. No.
30"	22"	71811
36"	22"	71812
48"	22"	71814

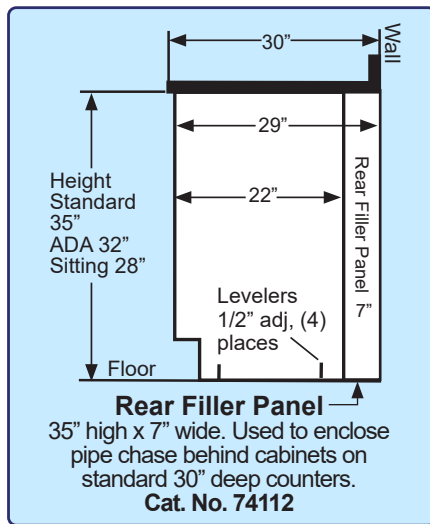

4 Drawer Cabinet

Width	Depth	Cat. No.
18"	22"	71221
24"	22"	71222

Standard Lab Bench Stands
with 1" Phenolic Resin worksurface

Mobile Table (Height adjustable 30", 32", 36"H)		
Width	Depth	Cat.No.
48"	30"	54812
72"	30"	57212

UniLine Laboratory Casework Construction (SEFA 8 Compliant)



Made in the USA

UniLine Casework is constructed of welded 18 gauge steel. Powder coat finish is environment friendly, attractive and long lasting, color: Lab White. Modular design allows for simple field conversion from inlet to overlay, door and drawer re-configurations and hardware component changes. Casework is tested independently to be SEFA 8 load bearing capacity compliant.

Drawer Bodies constructed of 20 gauge steel. 18 gauge drawer suspension with full extension ball bearing drawer slide. File drawer suspension available in both 100 and 150 lb capacity. Exterior is urethane powder coated steel, for chemical and abrasion resistance.

Doors double wall construction with 20 gauge reinforcing channel (1) per door. Rubber door bumpers (4) per door. Five knuckle hinges (2) per door. Nylon roller catch (1) per door. Urethane powder coated steel. Manual, self closing.

Cabinet Interior Full length & width adjustable 20 gauge steel shelf for maximum storage. Zinc plated adjustable steel shelf clips. Powder coated finish for chemical resistance. 18 gauge full height removable access panel. Color: Lab White



epoxy, stainless steel and phenolic worksurfaces available

Recessed Toe Space promotes laboratory cleanliness. Cabinet base lower corner reinforcing gusset with 0 to 2-1/2" zinc leveling bolts on (all four corners). Cabinet height adjustable from 35" to 37". 12 gauge steel corner gusset (4) each cabinet.

Laboratory Furniture Groupings

UniLine design incorporates our most popular casework groupings to meet your laboratory needs. Welded steel with chemical resistant, epoxy powder coat finish, and 1" thick phenolic resin countertops, 4" high backsplashes, and flush ends standard. Standard height 36", ADA height 34", and sitting height 28" options are available. Standard color: Lab White. (optional colors are available as required) Groupings can be supplied with optional Fume hoods.

Atlantis Grouping

Atlantis Grouping provides basic lab storage & a versatile work area. Cabinet grouping includes 3 standing height cabinets with rear filler panels on both ends, phenolic resin worksurface 36" high, with 4" high back splash. Includes 16" X 12" X 8" sink and H/C gooseneck faucet.

Atlantis Cabinet Grouping					
Width	1	2	3	24" Depth Cat. No.	30" Depth Cat. No.
108"	36"	36"	36"	70011	70021
120"	36"	48"	36"	70012	70022
144"	48"	48"	48"	70013	70023

Enterprise Grouping

Enterprise Grouping provides a convenient balance of storage and work space. Cabinet grouping includes 3 standing height cabinets with rear filler panels, 2 wall cabinets, phenolic resin worksurface 36" high, with 4" high back splash. Includes 16" X 12" X 8" sink, 30" X 30" pegboard and H/C gooseneck faucet.

Enterprise Cabinet Grouping					
Width	1	2	3	24" Depth Cat. No.	30" Depth Cat. No.
108"	36"	36"	36"	70211	70221
120"	36"	48"	36"	70212	70222
144"	48"	48"	48"	70213	70223

Endeavour Island Grouping

Endeavour Grouping is a flexible design that can serve as an island or peninsula layout. Cabinet grouping includes either 3 or 7 standing height cabinets with front and end filler panels, phenolic resin worksurface, and center island reagent shelf with pedestals and phenolic resin shelf. Includes 16" X 12" X 8" sink, 30" X 30" pegboard and H/C gooseneck faucet.

Endeavor Cabinet Grouping					
Width	1	2	3	4	Cat. No.
101"	36"	36"	—	60"	71311
137"	36"	36"	36"	60"	71312
173"	48"	48"	48"	60"	71313

Viking/Magellan Grouping

Viking Grouping is ideal for medical examination rooms and small lab requirements. Cabinet grouping includes 1 or 2 standing height cabinets, 1 wall cabinet 36" or 48" wide, 24" high 12" deep, phenolic resin worksurface. Includes 16" X 12" X 8" sink and H/C gooseneck faucet.

Viking Cabinet Grouping				
Width	1	2	24" Depth Cat. No.	30" Depth Cat. No.
72"	36"	36"	70413	70423
96"	48"	48"	70414	70424

Magellan Sink Cabinet Grouping			
Width	1	24" Depth Cat. No.	30" Depth Cat. No.
36"	36"	70611	70621
48"	48"	70612	70622

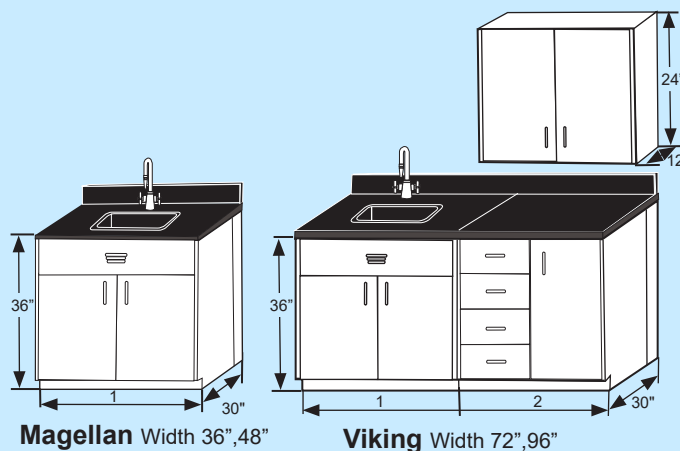
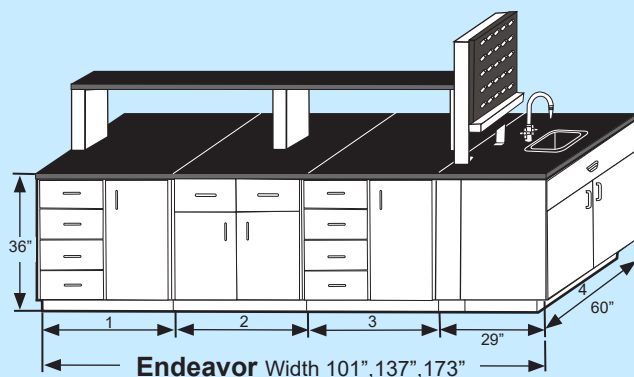
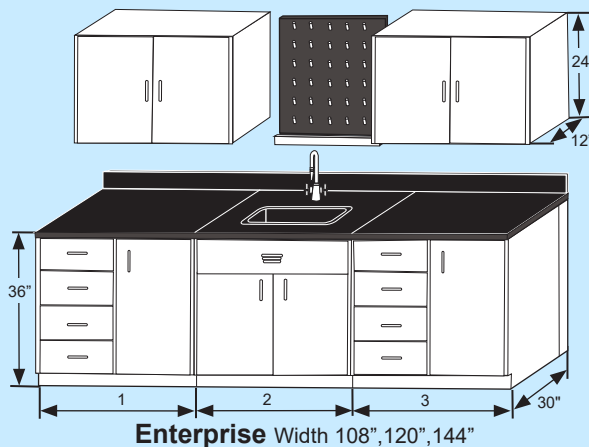
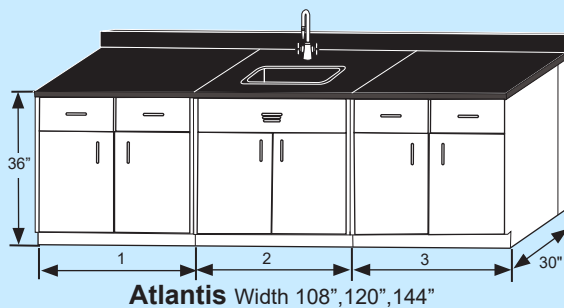

UniLine Furniture Groupings

Unitized design incorporates our most popular casework groupings to meet your laboratory needs. Welded steel with chemical resistant, epoxy powder coat finish, and 1" thick phenolic resin worksurface, 4" high backsplashes, and flush ends standard. ADA height 34" Max, and sitting height 28", options are available. Standard color: Lab White (optional colors are available as required)

Artemis Grouping

UniLine Artemis Grouping provides ample lab storage with options. Cabinet grouping includes (3) 36" high cabinets, phenolic resin worksurface, with 4" high back splash. Includes 16" X 12" X 8" sink and H/C gooseneck faucet, and three wall cabinets. Add a UniFlow SL fume hood in widths of 48", 60", 72", and 96" wide.

Artemis Cabinet Grouping					
Cat.No.	Length	1	2	Add a hood Select 48", 60", 72" or 96" SL	3
70901	108"	36"	36"		36"
70902	144"	48"	48"		48"

Ranger Grouping

UniLine Ranger Grouping combines convenient basic lab storage. Grouping includes (3) 36" high cabinets with rear filler panels on both ends, phenolic resin worksurface, with 4" high back splash. Add a UniFlow SL fume hood in widths of 48", 60", 72", and 96" wide.

Ranger Cabinet Grouping					
Cat.No.	Length	1	Add a hood Select 48", 60", 72" or 96" SL		3
70911	108"	36"	36"	36"	36"
70912	144"	48"	48"	48"	48"

Surveyor Grouping

UniLine Surveyor Grouping accommodates greater storage requirements. Grouping includes (3) cabinets 36" high, phenolic resin worksurface with 4" high backsplash, 16" X 12" X 8" sink, H/C gooseneck faucet and pegboard. Add a UniFlow SL fume hood in widths of 48", 60", 72", and 96" wide.

Surveyor Cabinet Grouping					
Cat.No.	Length	1	2	3	Add a hood Select 48", 60", 72" or 96" SL
70921	108"	36"	36"	36"	
70922	144"	48"	48"	48"	

Lunar Grouping

UniLine Lunar Grouping provides lab storage. Cabinet grouping includes (3) 36" high cabinets with rear filler panels on the ends, and one floor storage cabinet, phenolic resin worksurface, with 4" high back splash. Includes two wall cabinets. Add a UniFlow SL fume hood in widths of 48", 60", 72", and 96" wide.

Lunar Cabinet Grouping					
Cat.No.	Length	Add a hood Select 48", 60", 72" or 96" SL			
70931	108"	36"	36"	36"	
70932	144"	48"	48"	48"	

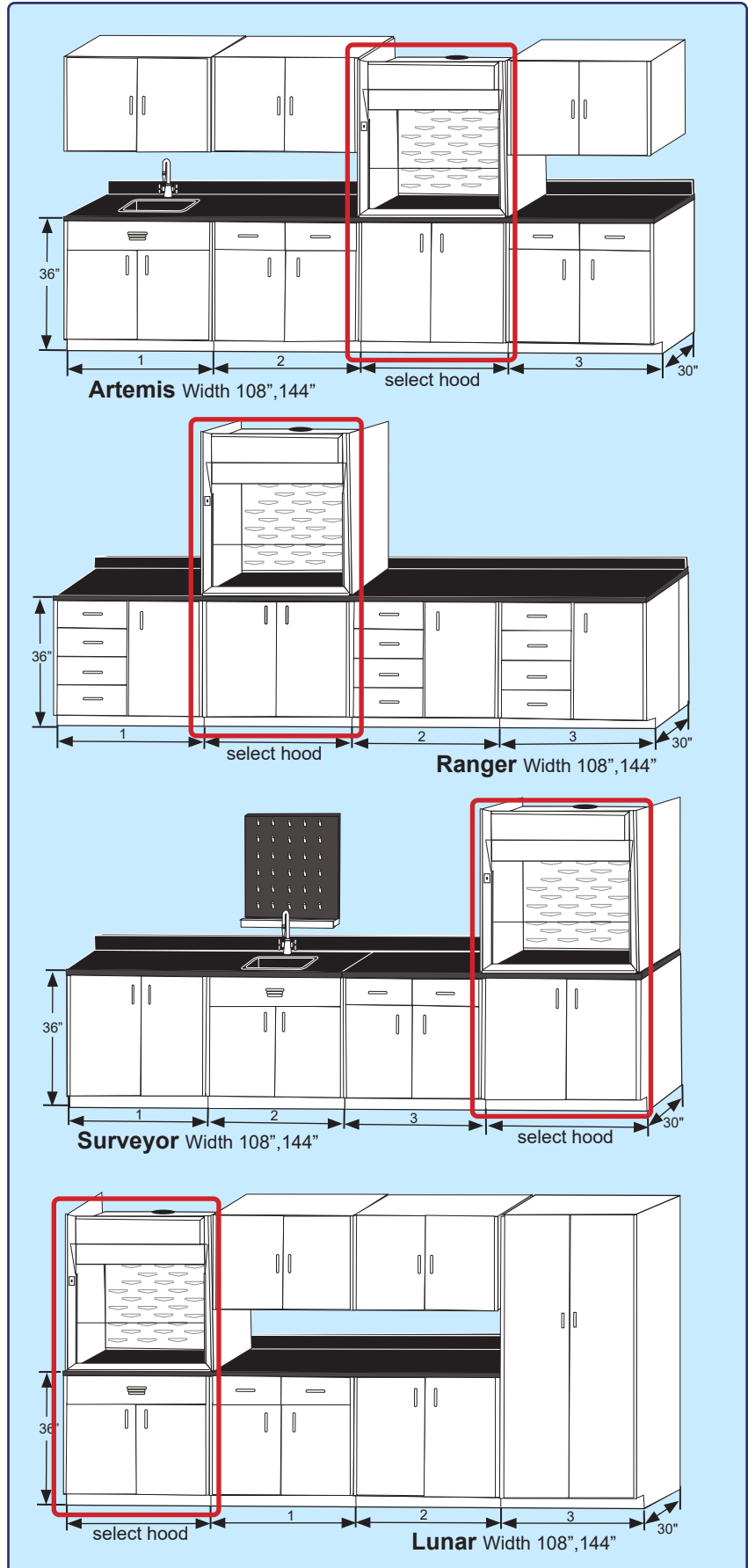

UniLine Furniture Groupings

Unitized design incorporates our most popular casework groupings to meet your laboratory needs. Welded steel with chemical resistant, epoxy powder coat finish, and 1" thick phenolic resin worksurface, 4" high backsplashes, and flush ends standard. ADA and sitting height options are available. Standard color: Lab White (optional colors are available as required)

Gemini Grouping

UniLine Gemini grouping features a sitting height desk area that can be incorporated with any of the HEMCO groupings. Cabinet grouping includes one sitting height file drawer cabinet with knee space panel, single apron, and phenolic resin worksurface. Sitting height 28".

Length	1	2	24" Depth Cat. No.	30" Depth Cat. No.
48"	30"	18"	70501	70521
54"	36"	18"	70502	70522
66"	48"	18"	70503	70523

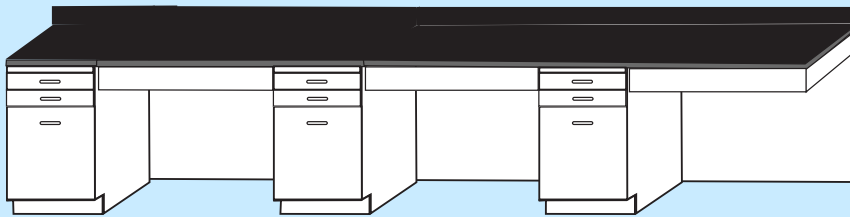

Example of (3) Gemini Groupings

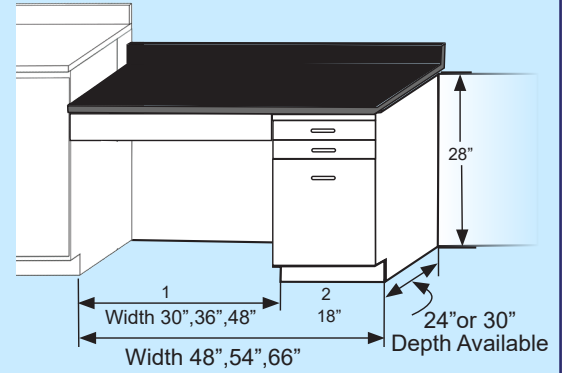

ADA

Freedom (ADA) Grouping Option

When ADA requirements are necessary, the UniLine Freedom Grouping option allows you specify any HEMCO casework grouping and be compliant to all dimension, space, and access standards as specified by ADA. In addition, all electrical services, plumbing accessories and safety equipment including emergency showers and eye wash stations are designed to meet ADA guidelines. Counter top height is 34". For ADA recommended reach see diagram 1 and 2.

Simply add "ADA" as a suffix to any HEMCO part number and HEMCO can design, quote, and supply ADA compliant equipment. Proper planning eliminates/reduces future problems. For a complete guide for all ADA technical information, including dimensions and standards, please visit: www.access-board.gov.

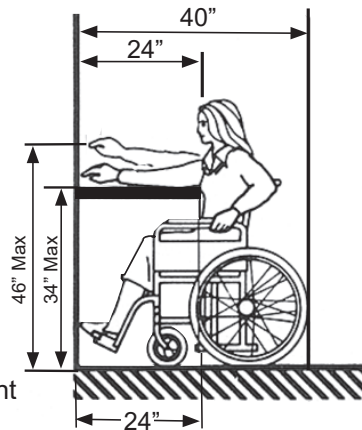

Diagram #1
Reach In

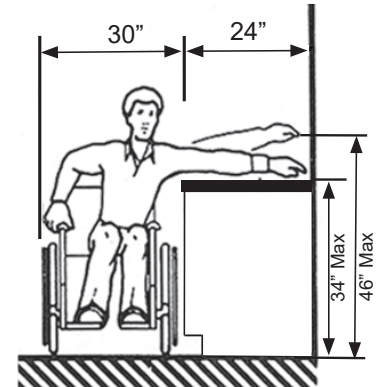
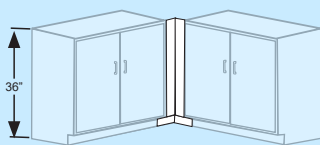

Diagram #2
Reach Over

Corner Grouping Solutions

HEMCO corner cabinets and fillers offer several means by which casework groupings or individual cabinets can be connected at a corner, eliminating unused corner space.



Basic Corner Scribe with worksurface
2" Cat. No. 74002

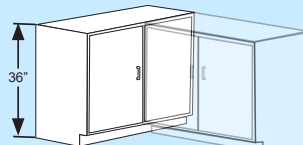

Overlap Corner Cabinet
36" Cat. No. 71981
48" Cat. No. 71983

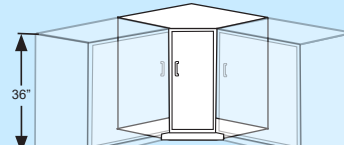

Spacious Corner Cabinet with worksurface
Cat. No. 71901

Corner Canopy



Corner Canopy Hoods

Analytical Test Laboratories Accessories

HEPA Filtered Air Module

Fan Powered Module

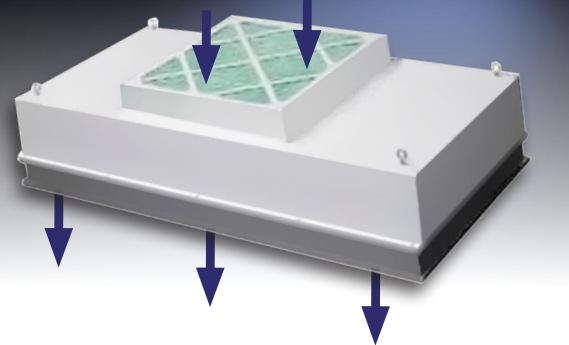

- Module features a 99.99% efficient @ 0.3 micron HEPA filter with, 90 FPM @ initial 0.47 w.g., 115v low watt A/C, 60Hz 1ph, includes prefilter, on/off/variable speed control, powder coated steel housing.
- HEPA filters can be changed from inside the enclosure, without removing the unit from the ceiling, can be ordered with optional integral lighting. Available with Magnehelic gauge **Cat. No. 51301**

Size	With out lights
24" X 48"	50324

Filter units feature an upstream gel channel on the final filter which provides a leak-free seal between the filter and the housing.

Replacement Filters

	Cat. No.
Prefilter, 30% efficient 20" X 20" X 1"	52190
HEPA filter 99.99% efficient (Inside Replaceable) (for 24" X 48" module)	52200

Clean Air In-Line Carbon Filtration Exhaust Systems

Note: HEMCO recommends a minihelic or magnehelic gauge to monitor the air flow differential across the filter. The static pressure indicated would alert when to change filter. The gauges can be hood or filter mounted. We recommend ordering a back-up replacement filter. Designed to clean up fume hood exhaust fumes. Carbon filtration removes unwanted odors & vapors. Select your fume hood exhaust blower from the chart below.

In-Line Carbon Filter Pak



Clean Aire Carbon Filter Pack

CFM	Size	Duct Size	Cat. No.
250-650	26" x 15" x 35 1/2"	4", 8" diameter	50297
650-1200	26" x 26" x 35 1/2"	8", 10", 12" diameter	50298

Carbon Filters			Prefilter (6 per carton)		
CFM	Size	Cat. No.	CFM	Size	Cat. No.
500	24" x 12" x 12"	52100	500	24" x 12" x 2"	52000
1000	24" x 24" x 12"	52101	1000	24" x 24" x 2"	52001

Fume Hood Epoxy Coated Steel Belt Drive Exhaust Blowers

Standard (STD) belt drive steel blower and impeller wheel are epoxy coated for superior chemical resistance. Explosion-proof blowers (EXP) have epoxy coated, non-sparking aluminum impeller wheel. V-belt drive and adjustable pulleys permit field balancing. Seven discharge positions to suit installation. Weather housing is furnished. Motor has thermal overload protection. Specify: 115V single phase, 230V single phase, 230/460V three phase or 208V(consult factory). 1 year manufacturer's warranty



Catalog Number and Static Pressure

CFM	A Inlet Dia	B1 Outlet Size	B2 Outlet Size	1/2" Static Pressure			3/4" Static Pressure			1" Static Pressure			1 1/2" Static Pressure		
				HP	STD	EXP	HP	STD	EXP	HP	STD	EXP	HP	STD	EXP
				296	8 7/8"	10 1/8"	4 1/8"	1/4	51701	51801	1/4	51702	51802	1/4	51703
800	8 7/8"	10 1/8"	6 3/8"	1/2	51713	51813	1/2	51714	51814	1/2	51715	51815	3/4	51716	51816
914	9 7/8"	11 1/2"	8 1/4"	1/2	51717	51817	1/2	51718	51818	—	—	—	—	—	—
1240	9 7/8"	11 1/2"	8 1/4"	1/2	51725	51825	1/2	51726	51826	3/4	51727	51827	3/4	51728	51828
1771	11 7/8"	13 3/8"	8 1/4"	1/2	51734	51834	3/4	51735	51835	3/4	51736	51836	1	51737	51837

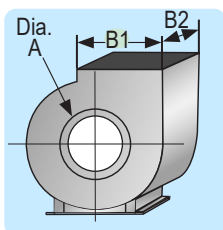

Laboratory Emergency / Shower Decontamination Booths

Full body emergency shower & eye / face wash, both with immediate response activation handle.

Durable one-piece seamless fiberglass construction with glass smooth white surfaces and covered corners for ease of clean-up.

Emergency showers available with translucent frosted strip curtains, which provides for easy access into booth, while containing contaminated water splash.

Stainless steel Grab bars located on right & left sides to support victim and rescue personnel during decontamination, included.

Plumbing is provided, for installation by local certified plumber. Plumbed to single point 1.25" IPT. connection. Tempered warm water supply connection 20 GPM water supply is required.

Raised fiberglass deck with self draining containment basin, and 2" diameter drain outlet located on either the bottom or rear of unit.

Industrial Applications
Emergency Drench Shower Booth
 unit is equipped with pull rod activated overhead drench shower and rear wall mounted eye/face wash.
Cat No. 16601

Laboratory Applications
Emergency Drench Shower Booth
 same specs as above except with finished exterior side panels.
Cat No. 16604



Cat. No. 16601
 For Industrial Applications
 shown above

Note: OSHA & ANSI require that emergency shower is to be located within 10 seconds walking time from the hazardous site location.



Overhead Drench Shower

Shower unit features 10" diameter plastic head and 1" IPS brass "stay open" valve with rigid pull rod and handle. **Cat. No. 16088**



Alarm Horn & Light
 Audible warning sound when system is activated by flow switch. Top mounted visual warning light when system is activated.
Cat. No. 16680



Eye/Face Wash

Wall mounting unit features two large plastic heads, push plate operated "stay open" ball valve. 1/2" IPS inlet, and 1.25" IPS drain. **Cat. No. 16006**

Eye and Face Wash Options



Hand Held Body Wash
 Squeeze valve nozzle on 8' coiled hose and bracket. Can be used to rinse all body parts while victim is sitting or lying down. Wall or hood mounted, 3/8 NPT, barrier free.

Cat No. 16005



Swing-Out Eye Wash

Deck mounted next to sink. Activates when pivoted. 1/2" NPT. Barrier free.

Cat. No. 16009



Hand Held Eye/Face & Body Wash

Mounted on the front side-wall of the fume hood. Includes 8' hose and surface escutcheon. 3/8" NPT. barrier free.

Cat. No. 93966

MODULAR LABS & CLEANROOMS

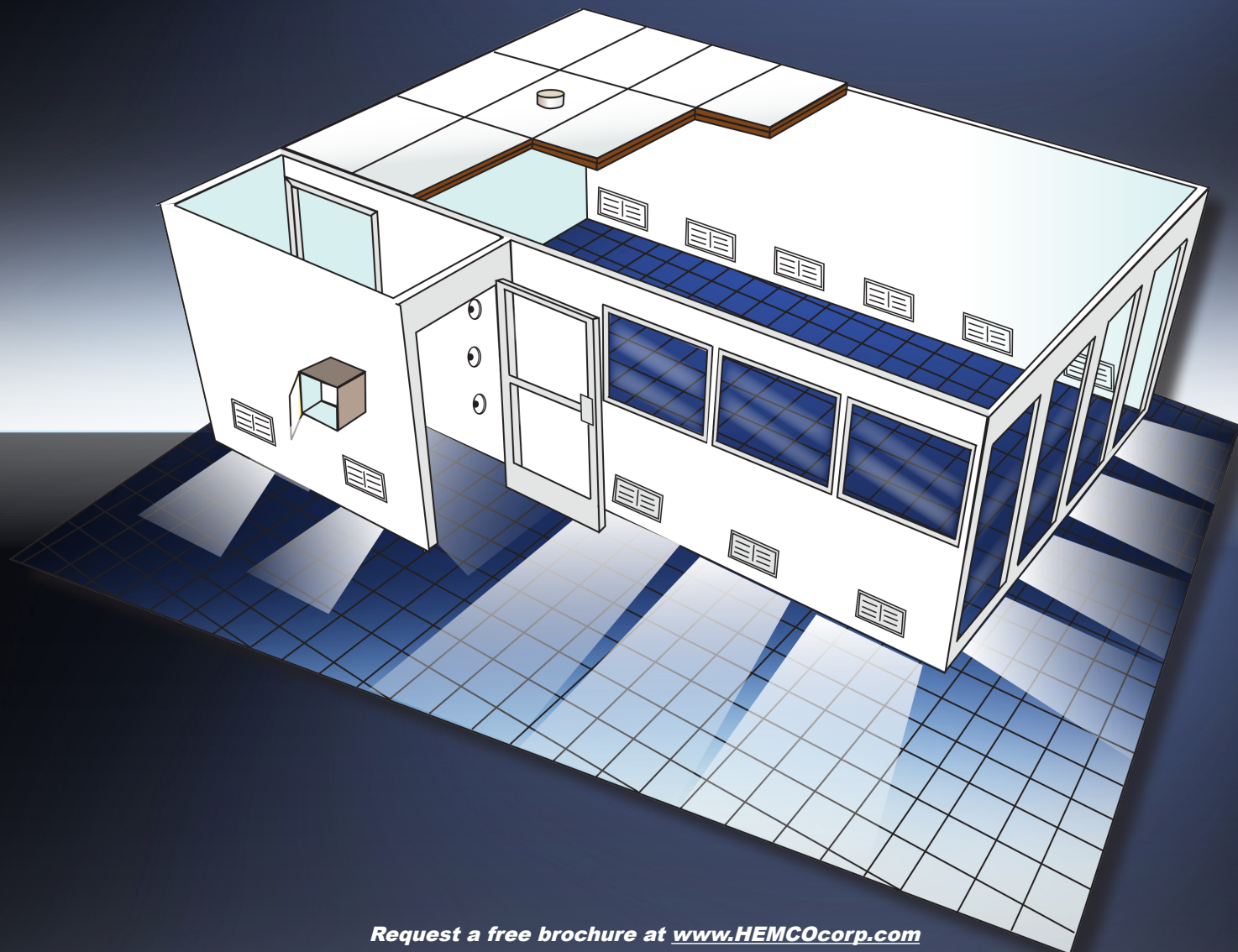

Request a free brochure at www.HEMCOcorp.com
and browse the entire selection of HEMCO Laboratory Equipment



EnviroMax Enclosures for Robotic and Automated Lab Processes



Laboratory Planning Solutions Complete Planning Guide



UniFlow Laboratory Fume Hoods Brochure



UniMax Large Floor Mount Walk-In Fume Hoods Brochure



HEMCO Corporation
711 South Powell Road
Independence, MO 64056
MCL-12.26

HEMCO

Laboratory Planning Solutions

Specify UNILAB Modular Clean Labs on Your Next Lab Project

For Prompt Service Call: (816) 796-2900

www.HEMCOcorp.com